



Post Office Box 97
 Benton Harbor, Michigan
 Ph: 269/926-6171
 Fax: 269/925-8288

PART NUMBER	STD464
REVISION	A

Product Specifications

Model Number	Motor Voltage	RPM		HP	kW	Net Wt.		Amps
		60 cycle	50 cycle			lbs.	kg	
0823-101Q-G279	208-230/380-460 60 HZ. 3PH.	1725	1425	3/4	0.56	47	21.3	2.4-2.6/1.1-1.4
	208-230/380-460 50 HZ. 3PH.							2.3-3.2/1.0-1.6

SOUND LEVEL LESS THAN 70 dB(A)
 NORMAL AMBIENT 1°C. - 40°C.
 RELATIVE HUMIDITY 8% - 100% NON CONDENSING
 ENVIRONMENT CLEAN DUST FREE

NOTES:
 1. TECHNICAL DATA SUBJECT TO CHANGE WITHOUT NOTICE.
 2. SOLID LINE IS FOR 60 CYCLE PERFORMANCE.
 DASHED LINE IS FOR 50 CYCLE PERFORMANCE.

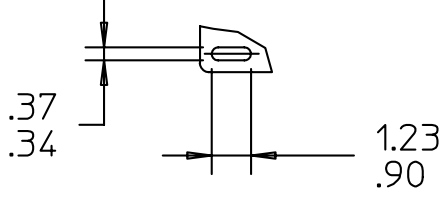
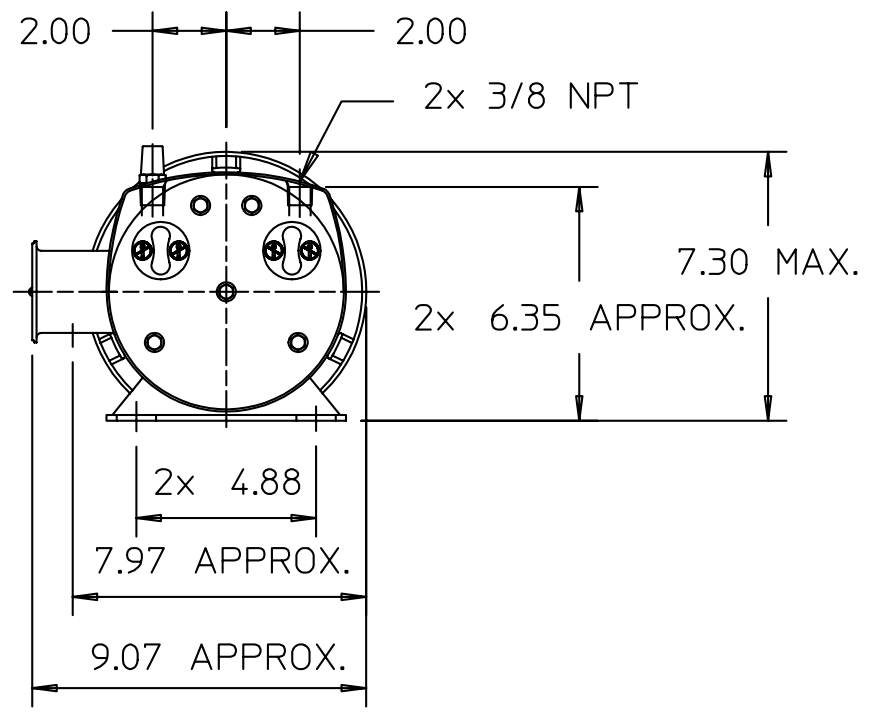
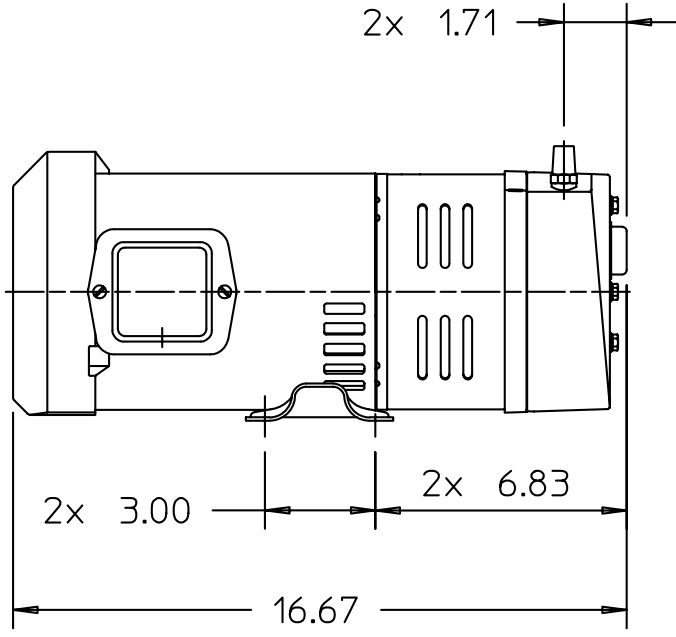
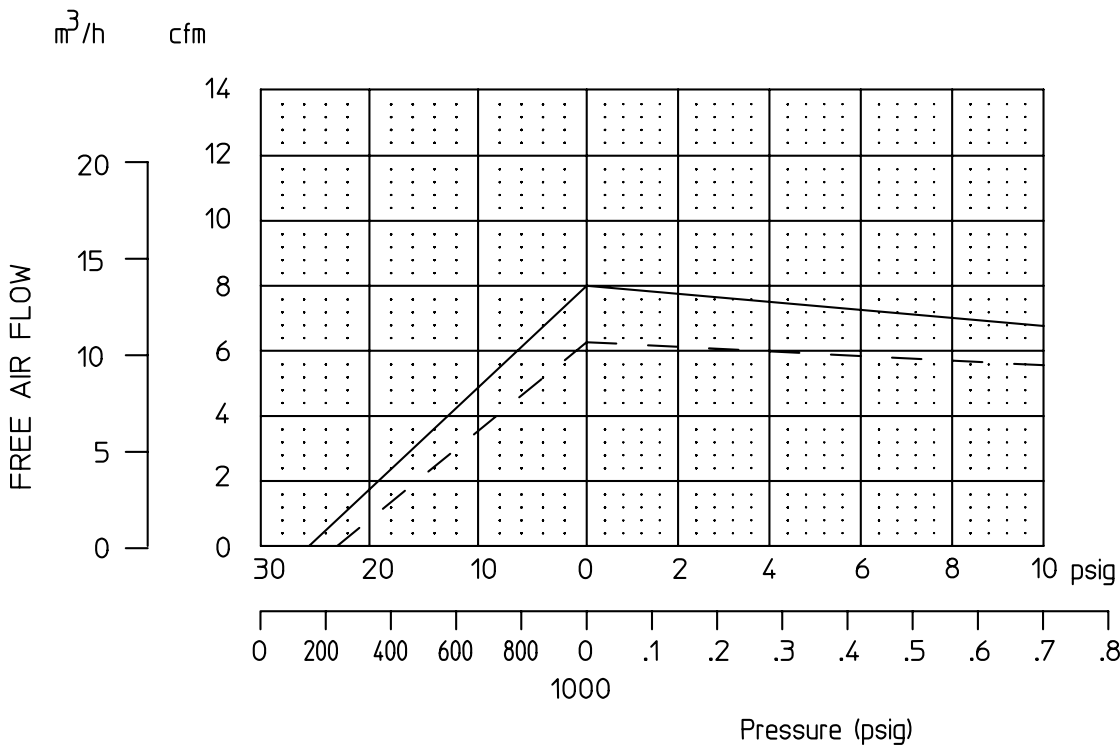

SLOT DETAIL
(TYP. 4)