



Post Office Box 97
 Benton Harbor, Michigan
 Ph: 269/926-6171
 Fax: 269/925-8288

PART NUMBER: STD124
 REVISION: K

Product Specifications

Model Number	MAX. PRESS.		MAX. SPEED	HP	kW	Net Wt.	
	bar.	PSI				lbs.	kg
4AM-NRV-50C	7.0	100	3,000 RPM	1.7	1.25	11	5.0
4AM-NRV-50L	7.0	100	3,000 RPM	1.7	1.25	11	5.0
4AM-NRV-50M	7.0	100	3,000 RPM	1.7	1.25	11	5.0
4AM-NRV-70C	7.0	100	3,000 RPM	1.7	1.25	11	5.0

TECHNICAL DATA SUBJECT TO CHANGE WITHOUT NOTICE. DIMENSIONS ARE FOR REFERENCE ONLY UNLESS OTHERWISE TOLERANCED.

SOUND LEVEL 87 dB(A) MAX.
 NORMAL AMBIENT +1° C. - 120° C.
 RELATIVE HUMIDITY 0% - 100%
 ENVIRONMENT HAZARDOUS AMBIENT COMBUSTIBLE GAS AND DUST +1°C TO +40°C

CONFORMS TO EUROPEAN STANDARD EN13463-1
 NON-ELECTRICAL EQUIPMENT FOR EXPLOSIVE ATMOSPHERES GROUP 11 CAT 2 (GAS & DUST), PROTECTED BY CONSTRUCTION (SURFACE TEMP. RATED 135C).

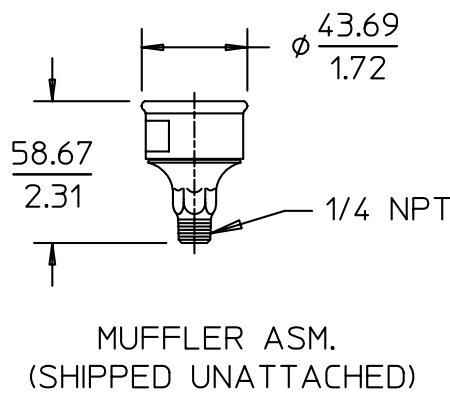
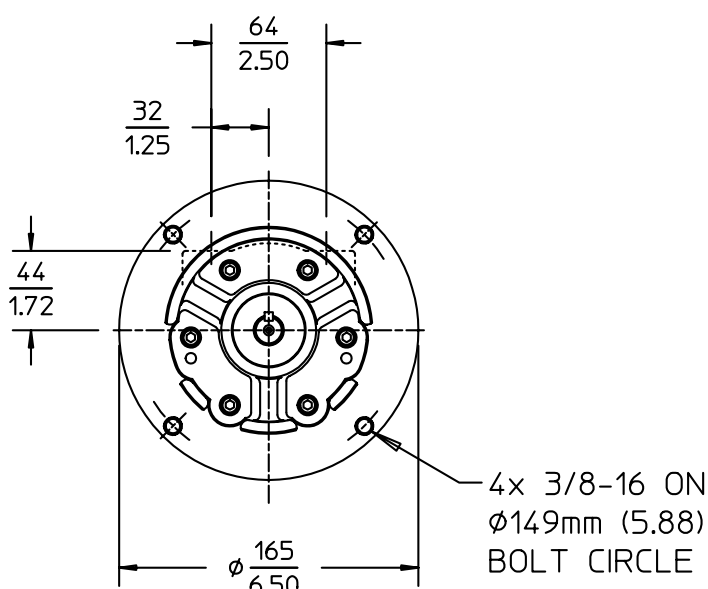
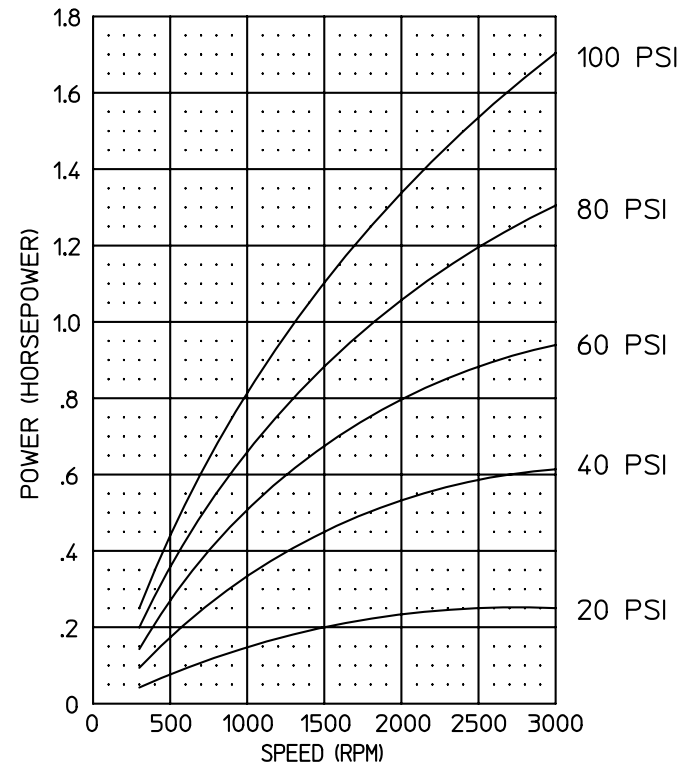
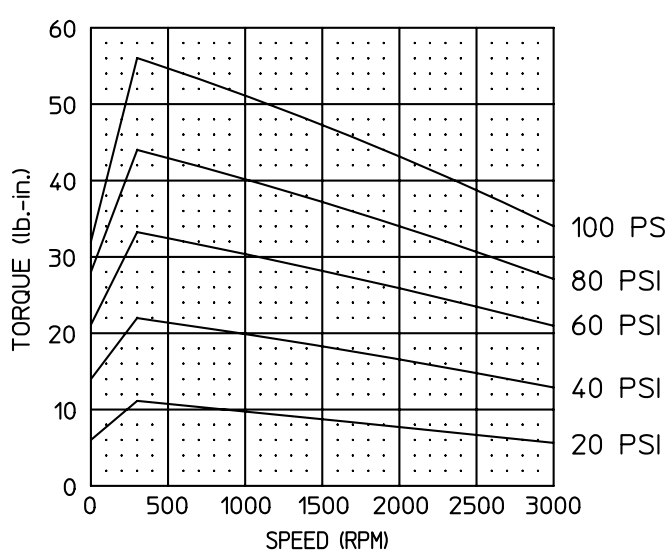
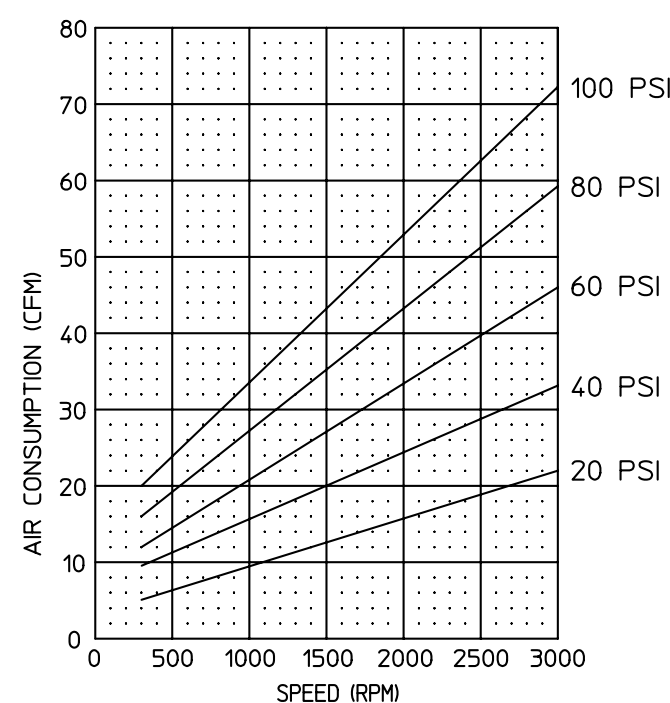
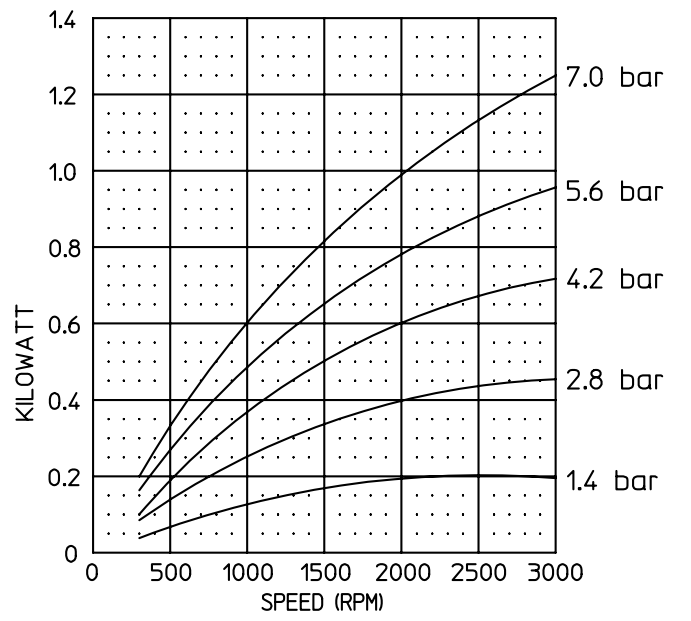
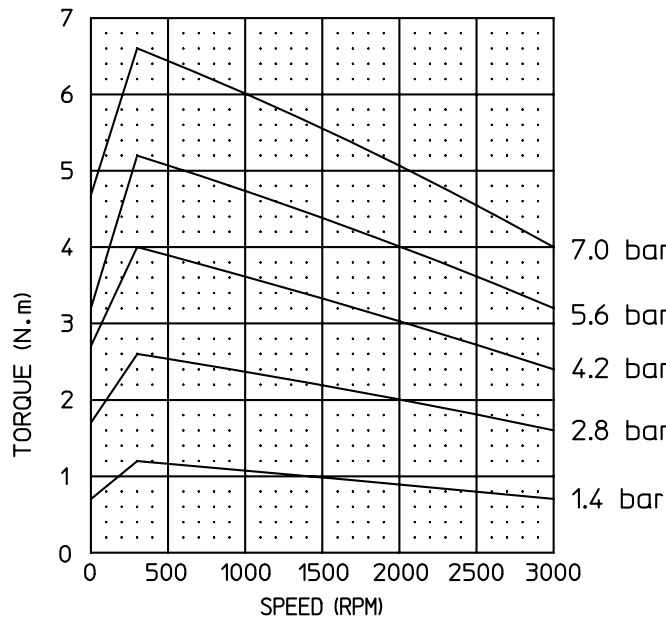
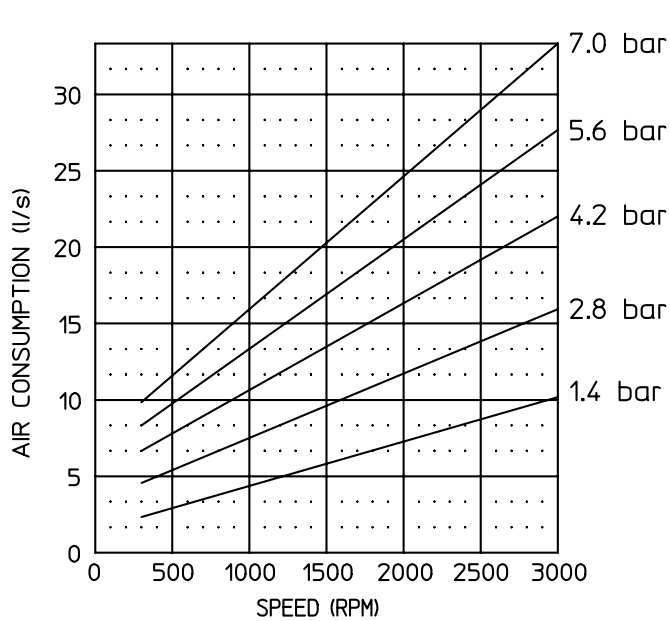

MUFFLER ASM.
(SHIPPED UNATTACHED)

