

0211 SERIES OIL-LESS VACUUM PUMPS & COMPRESSORS

OPERATION & MAINTENANCE MANUAL



Thank you for purchasing this Gast product. It is manufactured to the highest standards using quality materials. Please follow all recommended maintenance, operational and safety instructions and you will receive years of trouble free service.



WARNING



PLEASE READ THIS MANUAL COMPLETELY BEFORE INSTALLING AND USING THIS PRODUCT. SAVE THIS MANUAL FOR FUTURE REFERENCE AND KEEP IN THE VICINITY OF THE PRODUCT.

General information

- **Model numbers ending in "X"** have automatic thermal protectors which protect the motor by shutting the motor off if it overheats. The motor will automatically restart once the motor has cooled.

Product Use Criteria:

- Pump only clean, dry air.
- Operate at 32°F - 104°F (0°C - 40°C).
- Protect unit from dirt & moisture.
- Do not pump flammable or explosive gases or use in an atmosphere that contains such gases.
- Protect all surrounding items from exhaust air. This exhaust air can become very hot.
- Corrosive gases and particulate material will damage unit. Water vapor, oil-based contaminants or other liquids must be filtered out.
- Consult your Gast Distributor before using at high altitudes.
- Oil-Less rotary-vanes require NO lubrication.
- Sealed bearings are grease packed.
- Use of petroleum or hydrocarbon products will reduce carbon-vane service life.



ISO 9001 & 14001 CERTIFIED

www.gastmfg.com

Your safety and the safety of others is extremely important.

We have provided many important safety messages in this manual and on your product. Always read and obey all safety messages.



This is the safety alert symbol. This symbol alerts you to hazards that can kill or hurt you and others. The safety alert symbol and the words “DANGER” and “WARNING” will precede all safety messages. These words mean:



DANGER

You **will** be killed or seriously injured if you don't follow instructions.



WARNING

You **can** be killed or seriously injured if you don't follow instructions.

All safety messages will identify the hazard, tell you how to reduce the chance of injury, and tell you what can happen if the safety instructions are not followed.

INSTALLATION



WARNING



Electrical Shock Hazard

Disconnect electrical power at the circuit breaker or fuse box before installing this product.

Install this product where it will not come into contact with water or other liquids.

Install this product where it will be weather protected.

Electrically ground this product.

Failure to follow these instructions can result in death, fire or electrical shock.

Correct installation is your responsibility. Make sure you have the proper installation conditions and that installation clearances do not block air flow.

Blocking air flow over the product in any way can cause the product to overheat.

Mounting

This product can be installed in any orientation as long as flow of cool, ambient air over unit is not blocked. Mounting the product to a stable, rigid operating surface and using shock mounts will reduce noise and vibration.

Plumbing

Remove plugs from the IN and OUT ports. Connect with pipe and fittings that are the same size or larger than the product's threaded ports.

Accessories

The product's intake and exhaust filters will provide adequate filtration in most applications. Consult your Gast representative for additional filter recommendations. Install relief valves and gauges at inlet or outlet, or both, to monitor performance. Check valves are required to prevent back streaming through the pump.

Motor Control

It is your responsibility to contact a qualified electrician and assure that the electrical installation is adequate and in conformance with all national and local codes and ordinances.

Determine the correct overload setting required to protect the motor (see motor starter manufacturer's recommendations). Select fuses, motor protective switches or thermal protective switches to provide protection. Fuses act as short circuit protection for the motor, not as protection against overload. Incoming line fuses help to withstand the motor's starting current. Motor starters with thermal magnetic overload or circuit breakers protect motor from overload or reduced voltage conditions.

The wiring diagram attached to the product provides required electrical information. Check that power source is correct to properly operate the dual-voltage motor.

OPERATION



WARNING

Injury Hazard

Product surfaces become very hot during operation, allow product surfaces to cool before handling.

Air stream from product may contain solid or liquid material that can result in eye or skin damage, wear proper eye protection.

Failure to follow these instructions can result in burns, eye injury or other serious injury.

It is your responsibility to operate this product at recommended pressures or vacuum duties and room ambient temperatures.

Model numbers ending in "X" have automatic thermal protectors which protect the motor by shutting the motor off if it overheats. The motor will automatically restart once the motor has cooled.

Start Up

If motor fails to start or slows down significantly under load, shut off and disconnect from power supply. Check that the voltage is correct for motor and that motor is turning in the proper direction. If unit is extremely cold, let it warm up to room temperature before starting. Vane life will be drastically reduced if motor is not operating properly. Vanes can break or be damaged if motor/pump runs in the wrong direction.

MAINTENANCE



WARNING



Electrical Shock Hazard

Disconnect electrical power supply cord before performing maintenance on this product.

If product is hard wired into system, disconnect electrical power at the circuit breaker or fuse box before performing maintenance on this product.

Failure to follow these instructions can result in death, fire or electrical shock.



WARNING

Injury Hazard

Product surfaces become very hot during operation, allow product surfaces to cool before handling.

Air stream from product may contain solid or liquid material that can result in eye or skin damage, wear proper eye protection.

Flush this product in a well ventilated area.

Failure to follow these instructions can result in burns, eye injury or other serious injury.

General Maintenance

1. Release all pressure and vacuum from unit.
2. Remove glass filter/muffler jar.
3. Remove cartridges from intake and exhaust filters and inspect them.
 - a. Check for cuts and excessive foreign material.
 - 1) If any of these conditions exists, replace immediately.
 - 2) If filters look serviceable, go to step 4.
4. Clean them with compressed air and recheck for above conditions.
 - a. If any of these conditions from step 3 show up, then replace immediately.
5. Re-assemble.

Flushing

Flushing this product to remove excessive dirt, foreign particles, moisture or oil that occurs in the operating environment will help to maintain proper vane performance.

Use only Gast recommended flushing solvent or other non-petroleum based flushing solvent. Do Not use kerosene or ANY other combustible solvents to flush product.

Follow these steps to flush this unit:

1. Disconnect from power source.
2. Remove all plumbing and accessories connected to inlet and exhaust ports.
3. Remove filter/muffler assembly.
4. Reconnect power source and start up unit. Stay away from exhaust stream.
5. Add flushing solvent while unit is running.
Note: If using liquid solvent, pour several tablespoons directly into intake port; or if using Gast recommended spray solvent, spray solvent for 5-10 seconds (recommended to repeat 2-3 times) directly into intake port.

While adding solvent, listen for changes in motor sounds in unit.

- a. If motor sounds smooth out, go to step 6.
 - b. If motor sounds don't smooth out, install Service kit (see service kit instructions).
6. Plug inlet and continue to run unit for 45 seconds. Keep away from spray area.
 7. Turn unit off.
 8. Turn unit over onto its ports and drain any remaining solvent.
 9. Turn unit upright.
 10. Re-install plumbing and accessories.
 11. Run unit for approximately 5 seconds.
 12. Remove filter elements
 13. Clean them with same solvent used to flush unit, or with soap and water.
 14. Dry them completely before reinstalling.
- IMPORTANT:** If unit overheats or is noisy, stop unit immediately for repair. Return unit to closest Authorized Service Facility or perform following rebuild procedures, using Service Kit part #K218.

After solvent has passed through unit, replace filter assemblies. Before putting unit back into service, ensure that any external accessories such as relief valves and gauges have not been damaged.

SHUTDOWN PROCEDURES

It is your responsibility to follow proper shutdown procedures to prevent product damage. NEVER ADD OIL TO THIS OIL-LESS PUMP.

1. Disconnect plumbing.
2. Operate product for at least five minutes without plumbing.
3. Run at maximum vacuum for 10-15 minutes.
4. Repeat step 2.
5. Disconnect power supply.
6. Plug open ports to prevent dirt or other contaminants from entering product.

SERVICE KIT INSTALLATION



WARNING

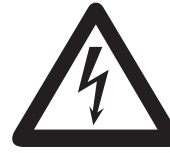

Electrical Shock Hazard

Disconnect electrical power supply cord before installing service kit.

If product is hard wired into system, disconnect electrical power at the circuit breaker or fuse box before installing service kit.

Vent all air lines to release pressure or vacuum.

Failure to follow these instructions can result in death, fire or electrical shock.

Gast will NOT guarantee field-rebuilt product performance. For performance guarantee, the product must be returned to a Gast-authorized facility.

Disassembly:

Service Kit contents vary. Most contain vanes, gaskets and filter parts. Refer to exploded view and follow these general instructions to install kit:

1. Remove muffler jar and muffler assembly.
2. Remove filter jar and filter assembly.
3. Remove six (6) bolts holding end plate to body.
4. Remove end plate and four (4) vanes.

NOTE: Do not remove rotor or loosen any electric motor through bolts.

5. Clean unit body and end plate.
6. Inspect unit parts for burrs.

Reassembly:

7. Insert vanes with scored side into rotor.
8. Reinstall endplate and bolts. Torque to 40 in-lb.
9. Replace filter/muffler felts.
10. Replace filter assembly.
11. Replace filter/muffler jars.



Disposal (Please note current regulations)

Parts of the rotary vane pumps and compressors, shafts, iron or aluminum castings, plastic or glass parts or bearings, may be recycled as scrap materials.

EXPLODED PRODUCT VIEW, PARTS & ORDERING INFORMATION

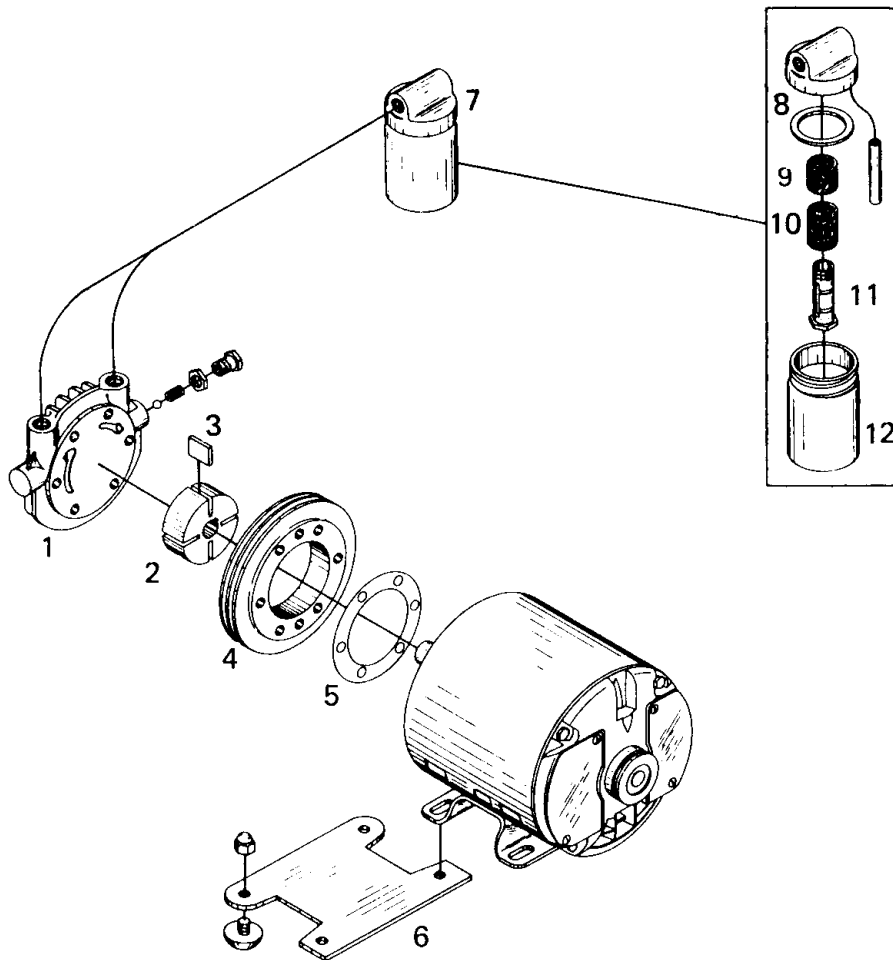

REF NO.	DESCRIPTION	QTY	0211-103A
1	END PLATE	1	AC130R
2	ROTOR	1	CM20J
3 Δ	VANE	4	AA348A
4	BODY	1	AC129
5 Δ	BODY SPACER	1	AA34
6	FOOT SUPPORT ASSEMBLY	1	AC136
7	FILTER/MUFFLER ASSEMBLY	1	AA617G
8 Δ	COVER GASKET	1	V400G
9 Δ	FILTER FELT	2	AA691
10	FILTER FELT	2	AA683A
11	SUPPORT STEM	1	AA808
12	GLASS JAR	2	AA690-43
***	SERVICE KIT	1	K218

Δ Denotes parts in the service kit.

Parts listed are for stock models. For specific OEM models, contact the factory. When corresponding or ordering parts, please give complete model number and serial number.

WARRANTY

Gast finished products, when properly installed and operated under normal conditions of use, are warranted by Gast to be free from defects in material and workmanship for a period of twelve (12) months from the date of purchase from Gast or an authorized Gast Representative or Distributor. In order to obtain performance under this warranty, the buyer must promptly (in no event later than thirty (30) days after discovery of the defect) give written notice of the defect to Gast Manufacturing Incorporated, PO Box 97, Benton Harbor Michigan USA 49023-0097 or an authorized Service Center (unless specifically agreed upon in writing signed by both parties or specified in writing as part of a Gast OEM Quotation). Buyer is responsible for freight charges both to and from Gast in all cases.

This warranty does not apply to electric motors, electrical controls, and gasoline engines not supplied by Gast. Gast's warranties also do not extend to any goods or parts which have been subjected to misuse, lack of maintenance, neglect, damage by accident or transit damage.

THIS EXPRESS WARRANTY EXCLUDES ALL OTHER WARRANTIES OR REPRESENTATIONS EXPRESSED OR IMPLIED BY ANY LITERATURE, DATA, OR PERSON. GAST'S MAXIMUM LIABILITY UNDER THIS EXCLUSIVE REMEDY SHALL NEVER EXCEED THE COST OF THE SUBJECT PRODUCT AND GAST RESERVES THE RIGHT, AT ITS SOLE DISCRETION, TO REFUND THE PURCHASE PRICE IN LIEU OF REPAIR OR REPLACEMENT.

GAST WILL NOT BE RESPONSIBLE OR LIABLE FOR INDIRECT OR CONSEQUENTIAL DAMAGES OF ANY KIND, however arising, including but not limited to those for use of any products, loss of time, inconvenience, lost profit, labor charges, or other incidental or consequential damages with respect to persons, business, or property, whether as a result of breach of warranty, negligence or otherwise. Notwithstanding any other provision of this warranty, BUYER'S REMEDY AGAINST GAST FOR GOODS SUPPLIED OR FOR NON-DELIVERED GOODS OR FAILURE TO FURNISH GOODS, WHETHER OR NOT BASED ON NEGLIGENCE, STRICT LIABILITY OR BREACH OF EXPRESS OR IMPLIED WARRANTY IS LIMITED SOLELY, AT GAST'S OPTION, TO REPLACEMENT OF OR CURE OF SUCH NONCONFORMING OR NON-DELIVERED GOODS OR RETURN OF THE PURCHASE PRICE FOR SUCH GOODS AND IN NO EVENT SHALL EXCEED THE PRICE OR CHARGE FOR SUCH GOODS. GAST EXPRESSLY DISCLAIMS ANY WARRANTY OF MERCHANTABILITY OR FITNESS FOR A PARTICULAR USE OR PURPOSE WITH RESPECT TO THE GOODS SOLD. THERE ARE NO WARRANTIES WHICH EXTEND BEYOND THE DESCRIPTIONS SET FORTH IN THIS WARRANTY, notwithstanding any knowledge of Gast regarding the use or uses intended to be made of goods, proposed changes or additions to goods, or any assistance or suggestions that may have been made by Gast personnel.

Unauthorized extensions of warranties by the customer shall remain the customer's responsibility.

CUSTOMER IS RESPONSIBLE FOR DETERMINING THE SUITABILITY OF GAST PRODUCTS FOR CUSTOMER'S USE OR RESALE, OR FOR INCORPORATING THEM INTO OBJECTS OR APPLICATIONS WHICH CUSTOMER DESIGNS, ASSEMBLES, CONSTRUCTS OR MANUFACTURES.

This warranty can be modified only by authorized Gast personnel by signing a specific, written description of any modifications.

MAINTENANCE RECORD

DATE	PROCEDURE PERFORMED

TROUBLESHOOTING CHART

Low		High		Pump Overheat	Motor Overload	Reason and remedy for problem.
Vacuum	Pressure	Vacuum	Pressure			
•	•	At pump		•	•	Filter dirty. Clean or replace.
	•		At pump	•	•	Muffler dirty. Clean or replace.
•		At pump		•	•	Vacuum line collapsed. Repair or replace.
		•	•	•	•	Relief valve set too high. Inspect and adjust.
•	•					Relief valve set too low. Inspect and adjust.
•	•	At pump	At pump	•	•	Plugged vacuum/pressure line. Inspect and repair.
•	•					Vanes sticking. Clean or replace.
•	•					Vanes worn. Replace.
•	•					Shaft seal worn. Replace.
•	•			•	•	Dust or offset powder in pump. Inspect and clean.
•	•			•	•	Motor not wired correctly. Check wiring diagram and line voltage.

Gast Manufacturing, Inc.

P.O. Box 97
2300 S. Highway M139
Benton Harbor, MI 49023-0097
Ph: 269/926-6171
FAX: 269/925-8288
www.gastmfg.com

Gast Hong Kong

Unit 12, 21/F, Block B
New Trade Plaza
6, On Ping Street, Shatin
N. T. Hong Kong
Ph: (852) 2690 1066
Fax: (852) 2690 1012
www.gasthk.com
FAX: 269/925-8288
www.gastmfg.com

**Gast Group Limited,
United Kingdom**

Unit 11, The I O Centre
Nash Road
Redditch, B98 7AS
United Kingdom
ph: +44 (0) 1527 504040
Fax: +44 (0) 1527 525262
www.gastmfg.com



ISO 9001 & 14001 CERTIFIED

www.gastmfg.com