

1/4 Tube Pilot-Operated Check Valve

Patents Pending

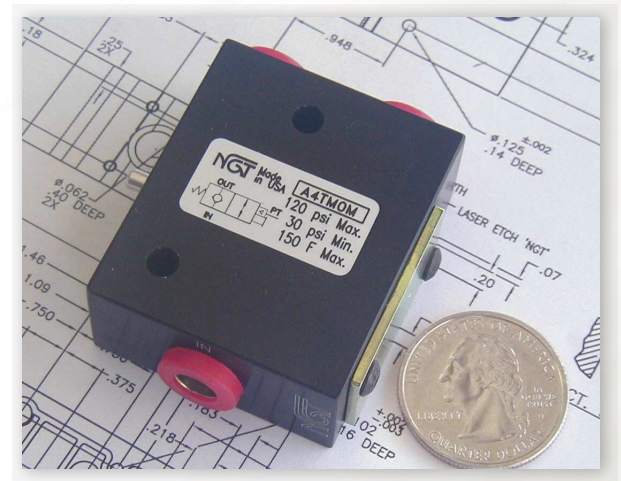
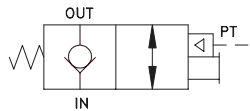
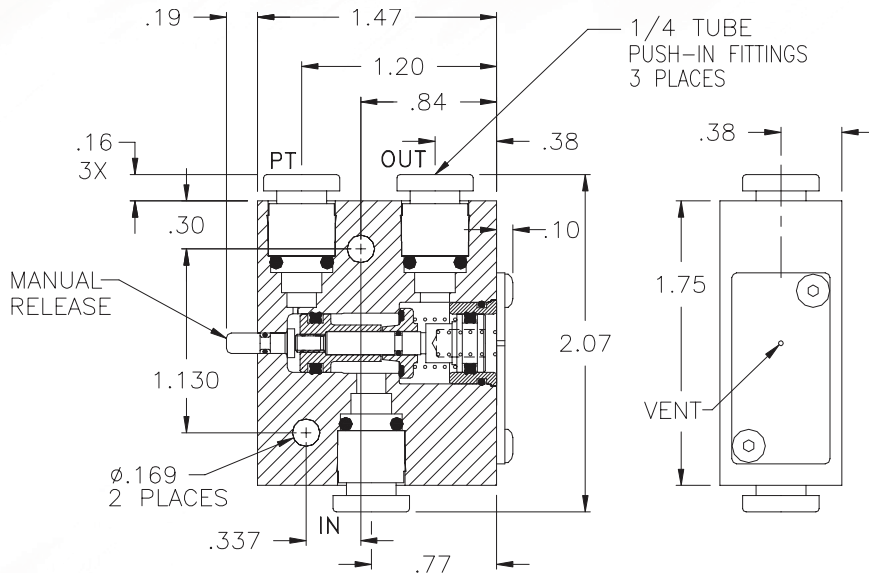

- New Smaller Size
- Push-on Connectors
- Manual Release
- .000113 cc/min Leak Rate

Basic Operation:

Lock your pneumatic device in position when a pressure drop or total loss of pressure occurs. Manual release for exhausting trapped air before maintaining the system (OSHA Requirement).

Operating Data:

| | |
|----------------------|--|
| Max. Pressure: | 120 psi |
| Min. Pilot Pressure: | 30 psi @ 80 psi |
| Leak Rate: | .000113 cc/min |
| Temp. Range: | 30 - 150 F |
| Cycle Rate: | 1 cyc./sec. max. |
| Flow Capacity (Cv): | .50 max. (or I.D. tube) |
| Cracking Pressure: | 2-3 psi |
| Service: | Properly filtered dry air or lubricated air. |

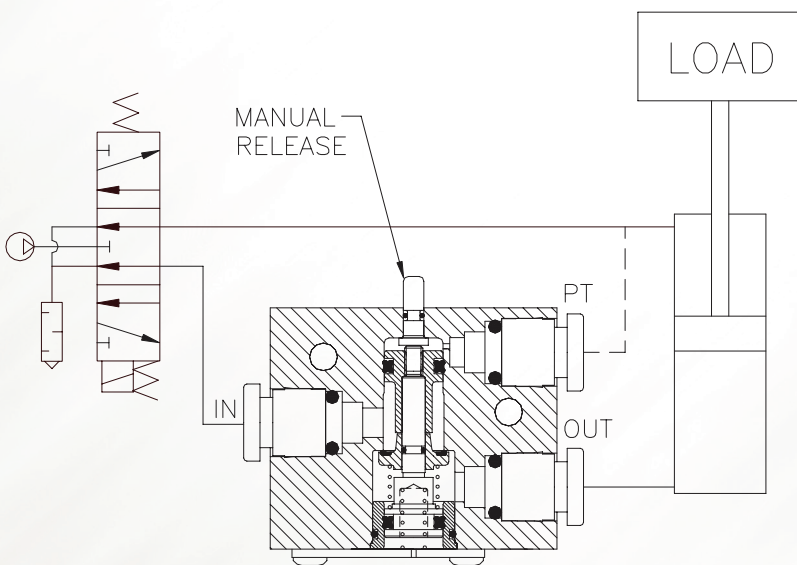

| | |
|----------------|----------|
| Model No. | 1/4 Tube |
| Manual Release | A4TM0M |